

LITHIUM BATTERY HYDRAULIC JACK



► EJ30-2ELS / EJ40-2ELS

► **Cordless Power**

Convenient, energy-efficient power for use anywhere

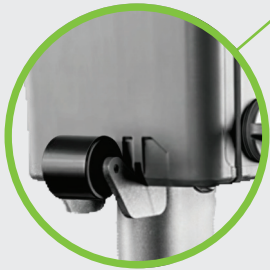

► **Anti Collision Wheel**
for Battery Pack protection

► **Elliptical Handle**

Stunning design with built-in connecting rod.

► **Multiple Adaptors**

Choose from two sizes to suit any situation

► **Industrial Seals**

High quality seal for maximum performance

► **Dual Safety Valve System**

Slow descent control and overload protection ensure safe, stable lifting



MODEL	EJ30-2ELS	EJ40-2ELS
Rated Voltage	36V	36V
Battery Qty	2pcs	2pcs
Capacity	▲ 30t / ▼ 15t	▲ 40t / ▼ 20t
Net Weight	40kg	46.5kg
Gross Weight	43kg	49kg
Packing Size	607x317x341mm	607x317x341mm

EJ30-2ELS

- A** 22.55 in
- B** 10.63 in
- C** 59.88 in
- E** 5.91 in
- F** 3.07 in
- G** 2.75 in
- K1** 2.95 in
- K2** 1.77 in
- α** 45°
- β** 35°

EJ40-2ELS

- A** 22.91 in
- B** 10.63 in
- C** 60 in
- E** 5.91 in
- F** 3.0 in
- G** 2.75 in
- K1** 2.95 in
- K2** 1.77 in
- α** 45°
- β** 35°

► **LED Lamp**
Locate lifting point with ease.

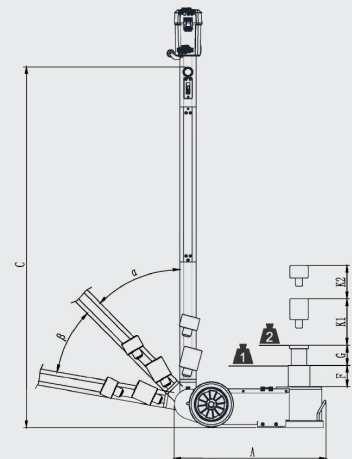
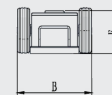

► **Dual Speed Piston Rod**

Fast rapid extension or Slow precise positioning.

► **Hard Chrome-Plated Cylinder:**

Enhanced durability and corrosion resistance for long service life