

LITHIUM BATTERY HYDRAULIC JACK



► EJ50-2



► Cordless Power

Convenient, energy-efficient power for use anywhere

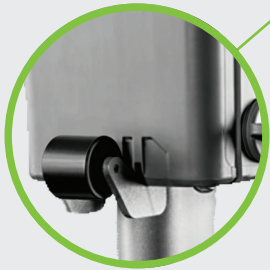

► Anti Collision Wheel for Battery Pack protection

► Elliptical Handle

Stunning design with built-in connecting rod.

► Multiple Adaptors

Choose from two sizes to suit any situation

► Industrial Seals

High quality seal for maximum performance

► Dual Safety Valve System

Slow descent control and overload protection ensure safe, stable lifting

MODEL EJ50-2

Rated Voltage	36V
Battery Qty	2pcs
Capacity	▲ 50t/▲ 25t
Net Weight	72.5kg
Gross Weight	76kg
Packing Size	779x329x343mm

- A 29.68 in
- B 10.63 in
- C 59.84 in
- E 8.46 in
- F 4.72 in
- G 4.61 in
- K1 2.95 in
- K2 1.77 in
- α 45°
- β 35°

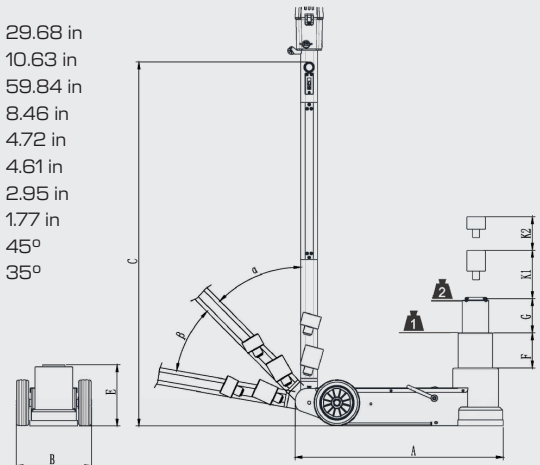

► LED Lamp

Locate lifting point with ease.

► Dual Speed Piston Rod

Fast rapid extension or Slow precise positioning.

► Hard Chrome-Plated Cylinder:

Enhanced durability and corrosion resistance for long service life